

mimatic®

T o o l S y s t e m s

2014/2015

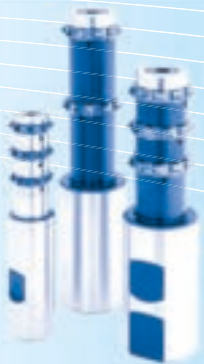

Manufacturer of Precision Tools since 1974

INNOVATION · PRECISION · INDIVIDUALITY · QUALITY · SERVICE

mimatic®

T o o l S y s t e m s

mimatic® GmbH

Westendstraße 3

D-87488 Betzigau

☎ +49 (0) 831 / 57444-0

📠 +49 (0) 831 / 57444-90

✉ info@mimatic.de

💻 www.mimatic.de

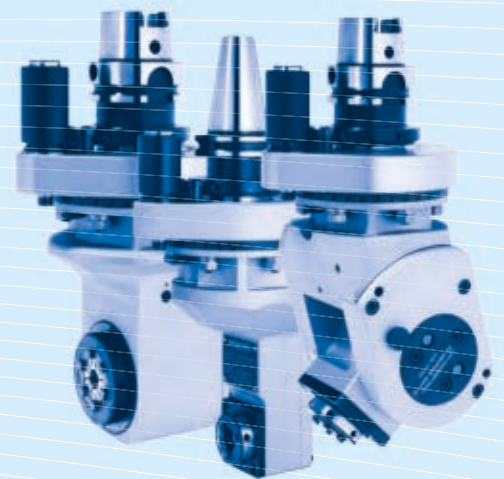
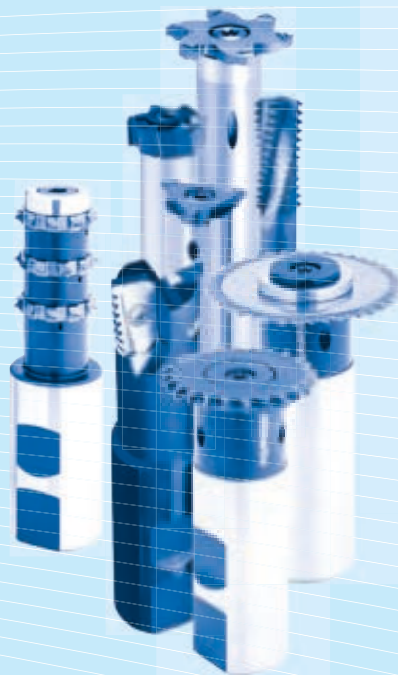

Our Company

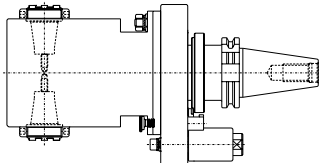
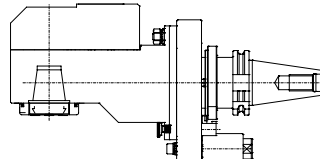
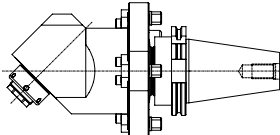

Table of Contents – Monoblock Angle Heads

	Type	DIN	Shank	Page
<p>SW</p> <p>Angle Head 90° Gear Ratio $i = 1:1$ Coolant supply: without / external / internal</p> 	SW	DIN 69871	SK 40	200
		DIN 69893 A	SK 50	205
			HKS 63	210
		MAS-BT JIS 6339	HSK 100	215
			BT 40	220
		BT 50	225	
		ANSI-CAT	CAT 40	230
			CAT 50	235
<p>DW</p> <p>Double Angle Head 90° Gear Ratio $i = 1:1$ Coolant supply: without / external</p> 	DW	DIN 69871	SK 40	201
		DIN 69893 A	SK 50	206
			HKS 63	211
		MAS-BT JIS 6339	HSK 100	216
			BT 40	221
		BT 50	226	
		ANSI-CAT	CAT 40	231
			CAT 50	236
<p>ZW</p> <p>Angle Head 90° Offset type Gear Ratio $i = 1:1$ Coolant supply: without / external / internal</p> 	ZW	DIN 69871	SK 40	202
		DIN 69893 A	SK 50	207
			HKS 63	212
		MAS-BT JIS 6339	HSK 100	217
			BT 40	222
		BT 50	227	
		ANSI-CAT	CAT 40	232
			CAT 50	237
<p>ZWS</p> <p>Angle Head 90° Offset Slim type Gear Ratio $i = 1:1$ Coolant supply: without / external</p> 	ZWS	DIN 69871	SK 40	203
		DIN 69893 A	SK 50	208
			HKS 63	213
		MAS-BT JIS 6339	HSK 100	218
			BT 40	223
		BT 50	228	
		ANSI-CAT	CAT 40	233
			CAT 50	238
<p>WS</p> <p>Angle Head, adjustable 0-98° Gear Ratio $i = 1:1$ or $1:2,25$ Coolant supply: internal</p> 	WS	DIN 69871	SK 40	204
		DIN 69893 A	SK 50	209
			HKS 63	214
		MAS-BT JIS 6339	HSK 100	219
			BT 40	224
		BT 50	229	
		ANSI-CAT	CAT 40	234
			CAT 50	239
<p>Angle Head with fixed angle</p> 	FW	Available on request.		

Angle Drilling Heads and Cutter Heads

mimatic® has been a reliable partner in project planning and the supply of precision tools worldwide for many years in the field of chip removing production.

In addition to toolholding systems and cutting tools, the company also provides driven tools for both CNC lathes and CNC machining centers to solve customer-specific problems with chip removal.

The company has provided many special purpose solutions for **angle heads and cutter heads** since its foundation in 1974. In doing so, mimatic has always placed special emphasis on **maximum precision, power transmission, operating safety and quality.**

We ensure close cooperation with our customers worldwide, providing advice on all machining problems – even on-site. We realize and implement our solutions on the basis of our **comprehensive standard program or by means of customer-specific special developments and designs.**

Our new standard program of **angle head tools** provides our customers with the means for complete, integrated machining. It is now no longer necessary to repeatedly relocate tools, which means a considerable reduction in production costs, rationalization and the increase in flexibility over the entire production process.

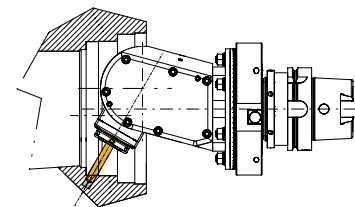
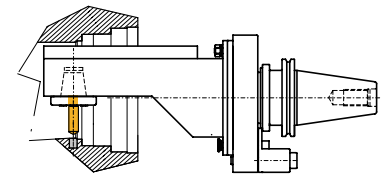
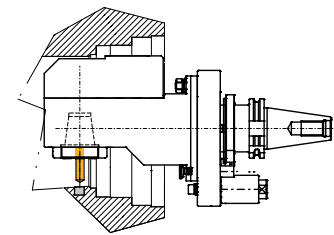
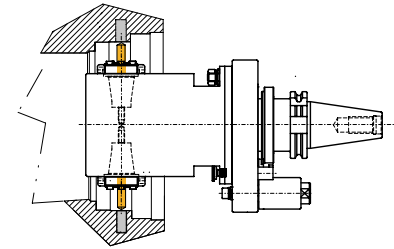
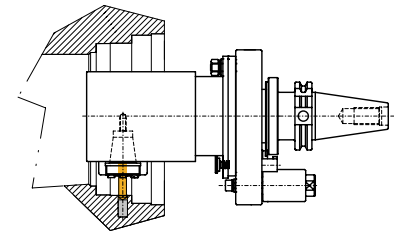

Features of the mimatic® Angle Heads

mimatic® angle heads increase the efficiency of your production. They allow you to work on inaccessible areas within housings or bores.

The angle heads can be used in all popular machine concepts, such as CNC machining centers with automatic or manual tool change and special-purpose machines with fixed insert. They are optimally designed for the respective machining task.

We use ground bevel gears with helical profile as well as hardened and ground spur gears to ensure smooth operation and high power transmission.

Versions

- mimatic® angle heads are available in all European and international shank variants:
 - **SK per DIN 69871, ANSI-CAT, MAS-BT and**
 - **HSK to DIN 69893 – Form A**
 other standards and sizes are also available on request
- With **standard torque support according to ISO 9524** (to be adapted by the customer)
- Available on request with 3-point support adapted to the machine and stop block
- Tool changing manual or automatic
- For drilling, reaming, countersinking, threading and milling
- Allows the machining of sections of the workpiece which are otherwise inaccessible (e.g. internal machining)
- A large number of special, customized designs for complex machining problems
- Single, dual or multi-spindle variants are available
- Fixed angles can be made, as opposed to using Adjustables or standard 90 Degree Heads
- Available on request with internal coolant supply via the spindle (70 bar)
- High torque transmission
- Available as standard with **collet chuck model „ER“ according to DIN 6499** or with our modular **„mi“ quick-change tool system** – compatible with all popular tool fittings (collet chucks, Weldon, Whistle-Notch, hydraulic chucks, shrink fit chucks, combi milling arbors, etc.)
- with mimatic® „SYNTAX“ thread quick-change chuck

mimatic „mi“

Modular quick-change tool system



mimatic „SYNTAX“

Tapping quick-change holder



Performance Values

The torques M_{max} specified in the tables below refer to shock-free processing (e.g. threaded cutting). For processes involving major shock loads (e.g. milling or multi-edge knocking), a value reduction of up to 50 % and more needs to be taken into account. The values n_{max} and P_{max} rendered are guideline values for short-time operation.

The permissible relative operating duration depends

- on the version of the spindle unit (with or without gear)
- on the presence of a cooling system and the type of cooling (external or internal through the tool spindle)
- on the processing torque

At a charge of about 60 % of the maximum values the working life calculated amounts to approx. 2.000 hours. Spindle units with gears produce more noise at higher speeds!

Operating Instructions

Initial Start-up: To ensure long tool life it is important to properly “run-in” the tools. This procedure serves to reduce the internal friction in the driven unit and to evenly distribute the grease in the precision bearings.

- **Max. RPM in the first operation hour should not exceed 70 % of the maximum permissible RPM.**
- **Never run the tool above the maximum permissible torque rate and/or maximum permissible RPM (see also the drawing of the unit).**

Tools with internal coolant through the spindle (i.C.): To avoid premature wear and damage to the seal system we recommend to filter the coolant to 40 μm minimum.

Filter grades of 40 μm worked in operation with very good results. The maximum permissible coolant pressure can be taken from the technical data of the driven toolholder.

Driven Toolholders with internal coolant through the spindle (i.C.) should **never run without coolant**. The coolant should flow through the tool, before the tool drive is switched on. Running in dry condition damages the internal seals.

Service interval: The tool life of the driven toolholder depends strongly on the application. Wear parts such as bearings and seals should be exchanged. We recommend to send the tools at least once annually to our service center for cleaning and regreasing. Tools with internal coolant through the spindle should be serviced every 6 months.

Optimum relative cycle times (guideline values)

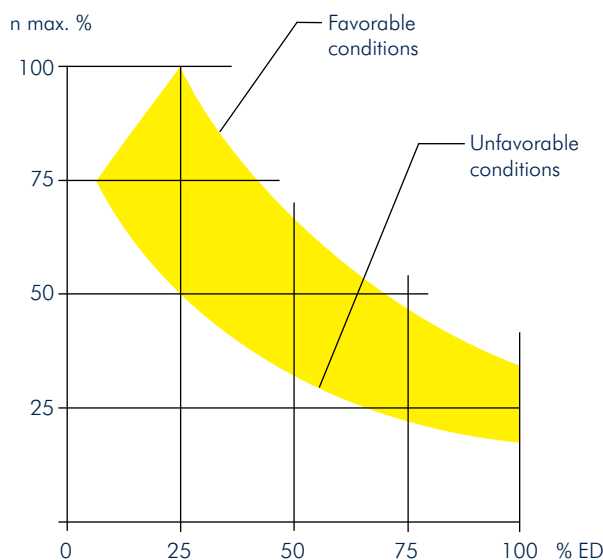

Determination of the maximum permissible cycle times per minute ED_{max}

The maximum permissible cycle times per minute may not be under any circumstances exceeded.

CT max: maximum permissible cycle times in percent per minute (%/min.)

Features of the Standard Angle Heads

- **Extremely precise Bearing Technology**
- **High Concentricity**
- **High Rigidity**

mimatic® angle heads are designed in such a way that they increase the quality of your workpieces and the service life of your tools.

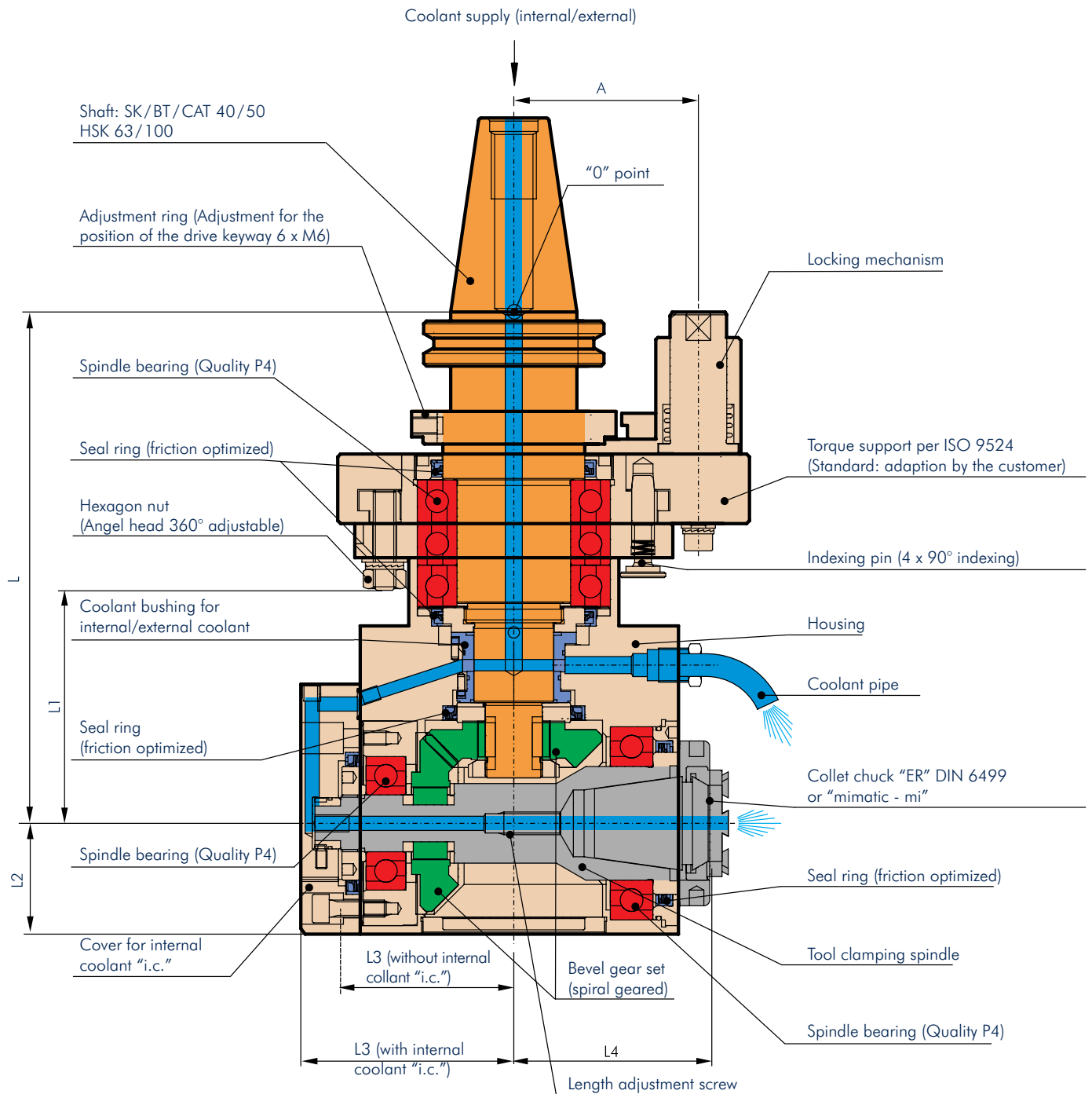

SK 40

WS

Connectable in accordance with **BLUECOMPETENCE** » mimatic mi » PolyMILL » TriMILL » PolyREAM

Angle Head, Adjustable 0-98°

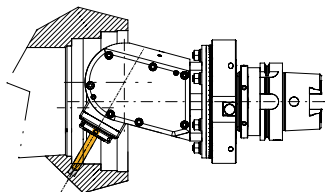

Adjustable angle unit to do boring and milling applications at any angle.

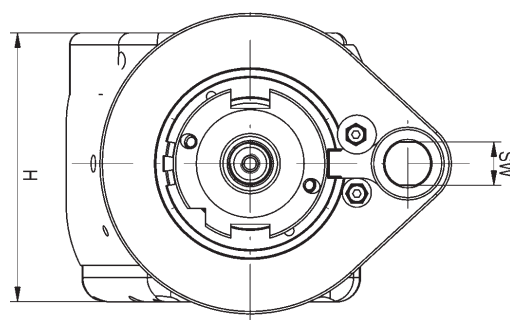
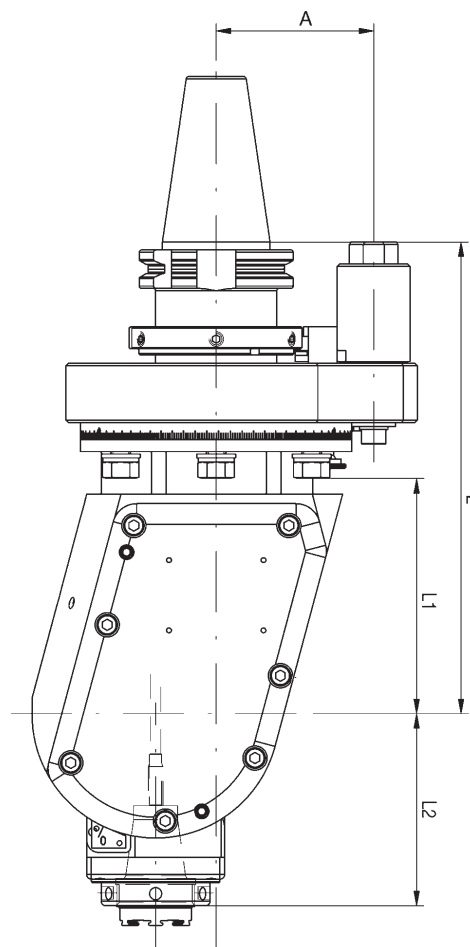
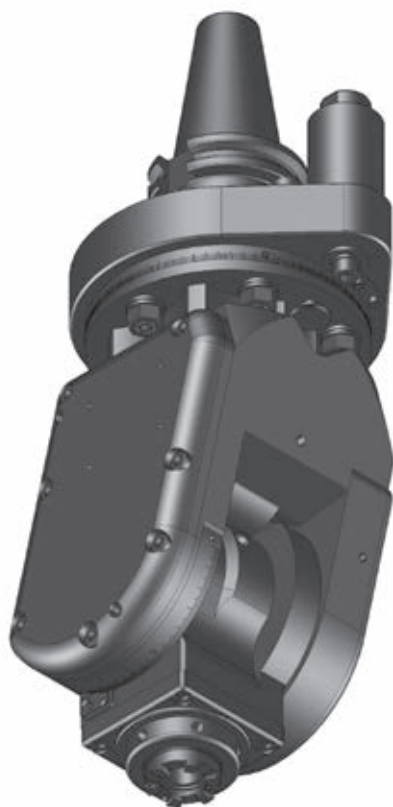

Size	Torque max.	Rev. max. (r.p.m.)	Gear Ratio	L mm	L1 mm	H mm	A mm	kg	SW
3	15 Nm	8.000 / 15.000	i = 1:1 / 1:2,25	189	91	96	65	8,0	18
5	30 Nm	7.000 / 13.500	i = 1:1 / 1:2,25	195	96	111	65	9,6	18

Size	Toolholder	L2 mm	L4 mm	Order No. (i=1:1)		Order No. (i=1:2,25)	
				without coolant	internal coolant	without coolant	internal coolant
3	ER 20	75,0	20	162793	105825	156560	105823
3	mi 32	82,9	20	156561	105832	156562	156563
5	ER 25	84,0	25	174413	105833	156580	105826
5	mi 40	97,0	25	162952	169975	162953	162954

SK 50

WS

Angle Head, Adjustable 0-98°

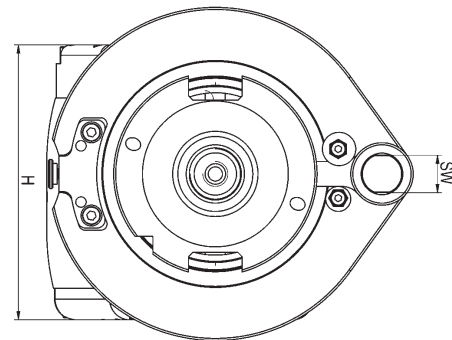
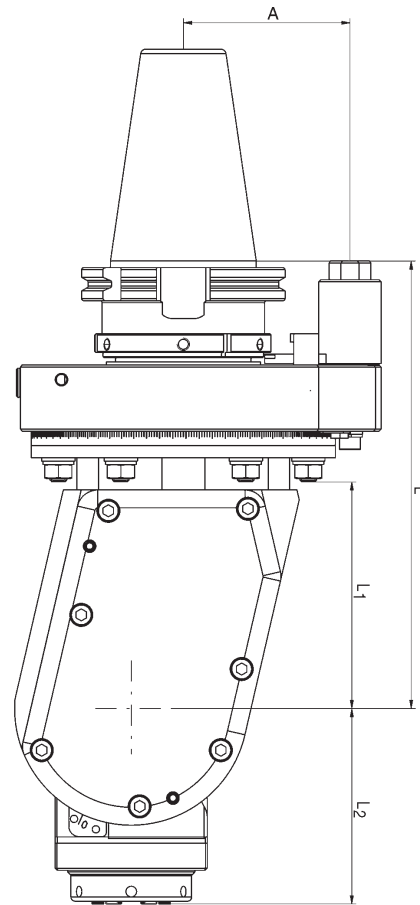
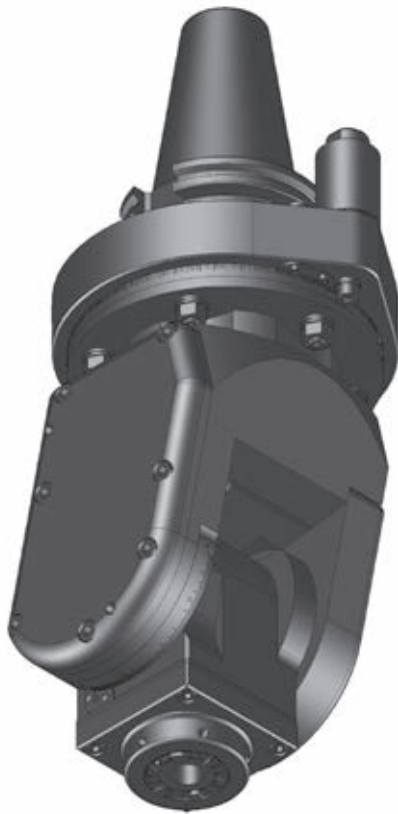
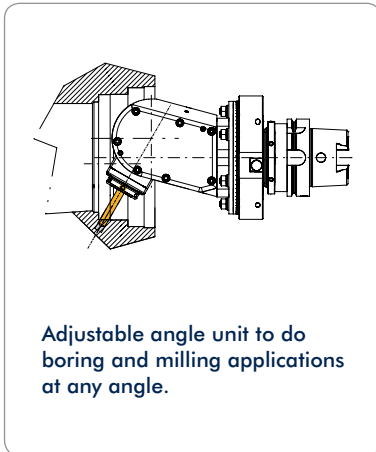

Size	Torque max.	Rev. max. (r.p.m.)	Gear Ratio	L mm	L1 mm	H mm	A mm	kg	SW
5	30 Nm	7.000 / 13.500	i = 1:1 / 1:2,25	195	96	111	80	14,0	18
7	70 Nm	6.000	i = 1:1	215	108	132	80	16,0	18

Size	Toolholder	L2 mm	L4 mm	Order No. (i=1:1)		Order No. (i=1:2,25)	
				without coolant	internal coolant	without coolant	internal coolant
5	ER 25	84	25	162965	135816	135823	162966
5	mi 40	97	25	162967	167021	162968	162969
7	ER 32	95	25	162982	105864		
7	mi 50	108	25	162989	166981		

12

HSK 63

WS

Connectable in accordance with
BLUECOMPETENCE » mimatic mi
» PolyMILL » TriMILL » PolyREAM

Angle Head, Adjustable 0-98°

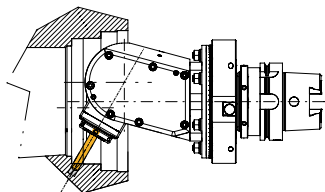

Adjustable angle unit to do boring and milling applications at any angle.

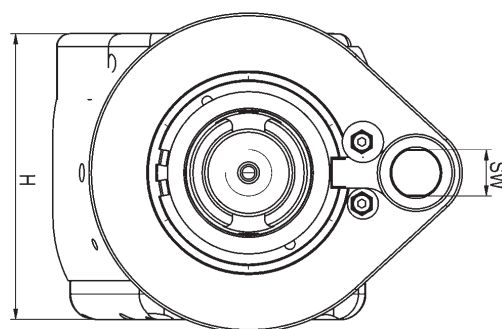
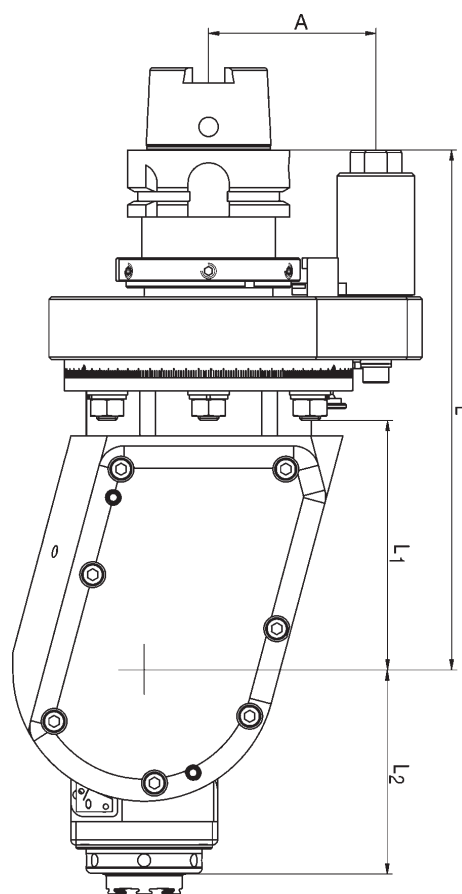
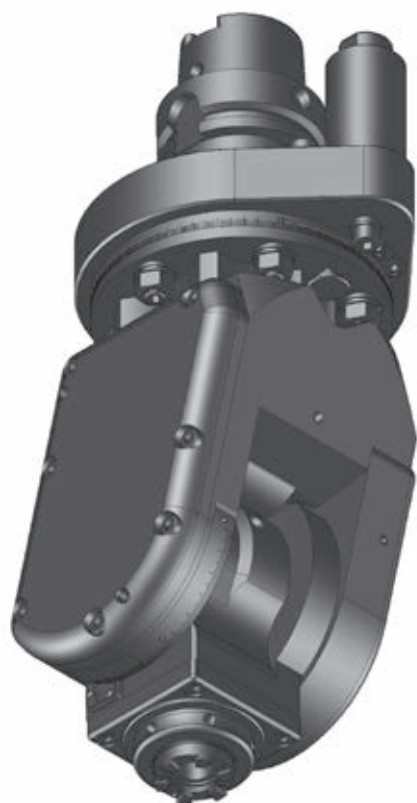

Size	Torque max.	Rev. max. (r.p.m.)	Gear Ratio	L mm	L1 mm	H mm	A mm	kg	SW
3	15 Nm	8.000 / 15.000	i = 1:1 / 1:2,25	196	91	96	65	8,0	18
5	30 Nm	7.000 / 13.500	i = 1:1 / 1:2,25	202	96	111	65	9,6	18

Size	Toolholder	L2 mm	L4 mm	Order No. (i=1:1)		Order No. (i=1:2,25)	
				without coolant	internal coolant	without coolant	internal coolant
3	ER 20	75,0	20	162945	105840	156558	156559
3	mi 32	82,9	20	156577	169142	156578	156579
5	ER 25	84,0	25	162961	135824	162962	135832
5	mi 40	97,0	25	162963	105853	162964	105858

HSK 100 **WS**

Angle Head, Adjustable 0-98°

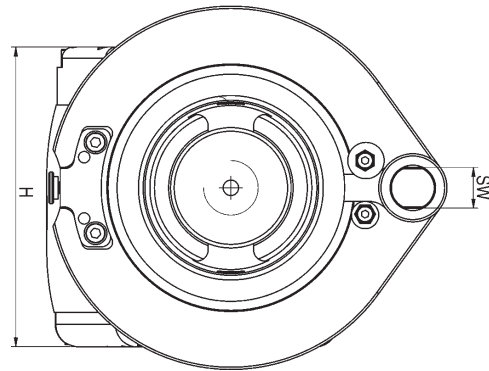
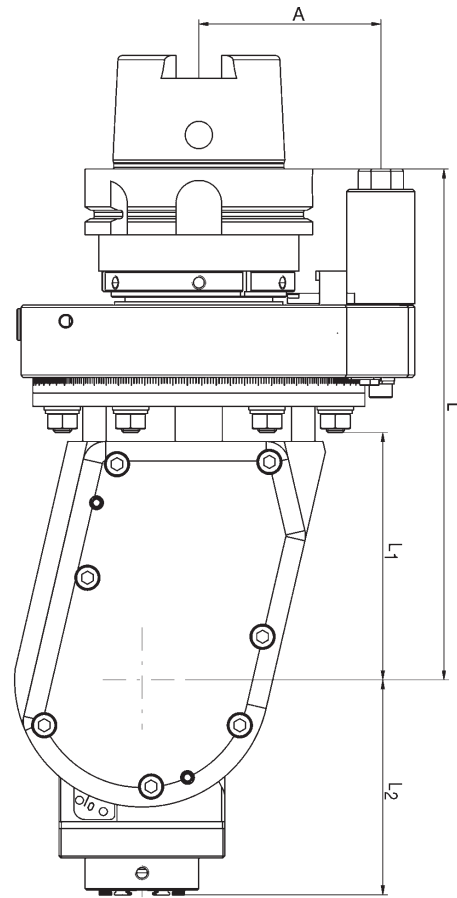
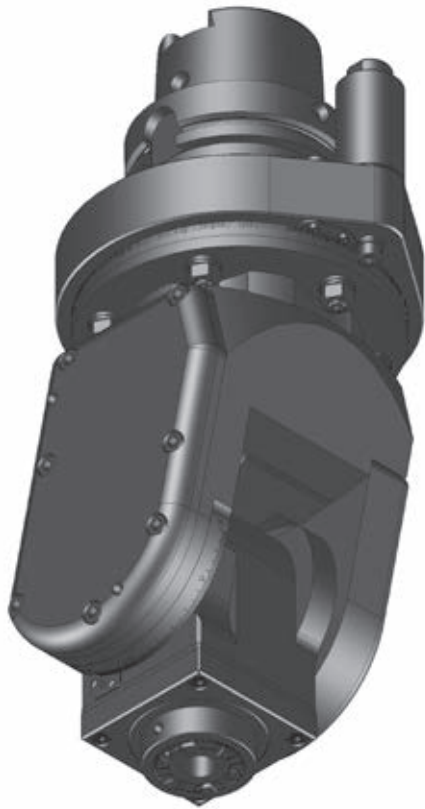
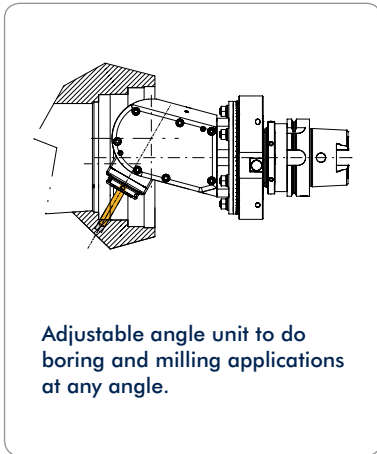

Size	Torque max.	Rev. max. (r.p.m.)	Gear Ratio	L mm	L1 mm	H mm	A mm	kg	SW
5	30 Nm	7.000 / 13.500	i = 1:1 / 1:2,25	205	96	111	80	14,0	18
7	70 Nm	6.000	i = 1:1	225	109	132	80	16,0	18

Size	Toolholder	L2 mm	L4 mm	Order No. (i=1:1)		Order No. (i=1:2,25)	
				without coolant	internal coolant	without coolant	internal coolant
5	ER 25	84	25	162976	135865	162977	162978
5	mi 40	97	25	162979	169980	162980	162981
7	ER 32	95	25	162986	105866		
7	mi 50	108	25	162991	169942		

MAS-BT 40 **WS**

Angle Head, Adjustable 0-98°

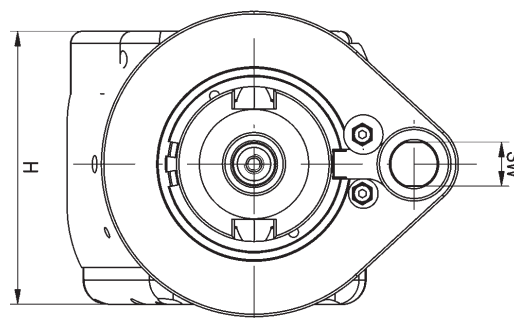
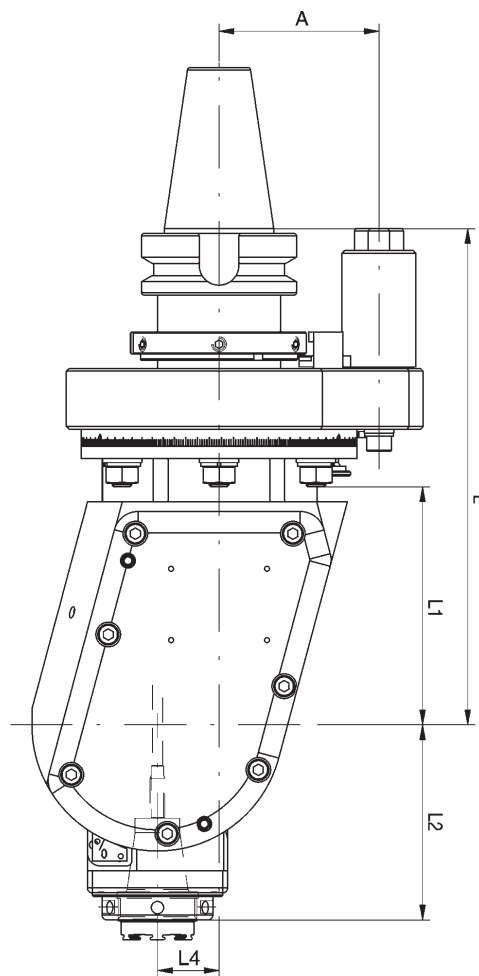
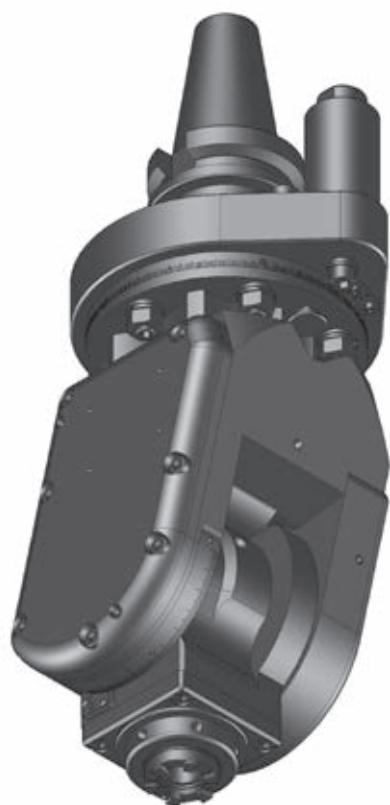
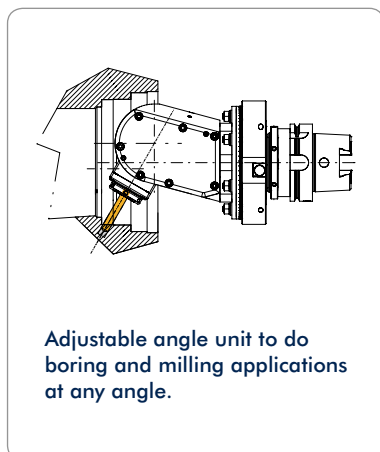

Size	Torque max.	Rev. max. (r.p.m.)	Gear Ratio	L mm	L1 mm	H mm	A mm	kg	SW
3	15 Nm	8.000 / 15.000	i = 1:1 / 1:2,25	196	100	96	65	8,0	18
5	30 Nm	7.000 / 13.500	i = 1:1 / 1:2,25	202	100	111	65	9,6	18

Size	Toolholder	L2 mm	L4 mm	Order No. (i=1:1)		Order No. (i=1:2,25)	
				without coolant	internal coolant	without coolant	internal coolant
3	ER 20	75,0	20	173907	105808	162858	162933
3	mi 32	82,9	20	156569	167418	156570	156574
5	ER 25	84,0	25	162955	135813	162957	162956
5	mi 40	97,0	25	162958	169976	162959	162960

MAS-BT 50

WS

Angle Head, Adjustable 0-98°

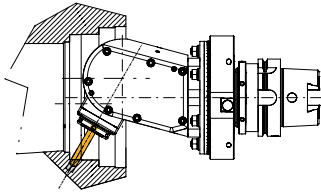

Adjustable angle unit to do boring and milling applications at any angle.

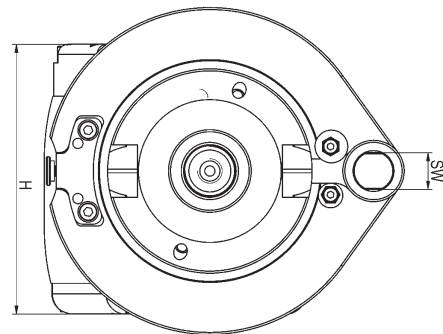
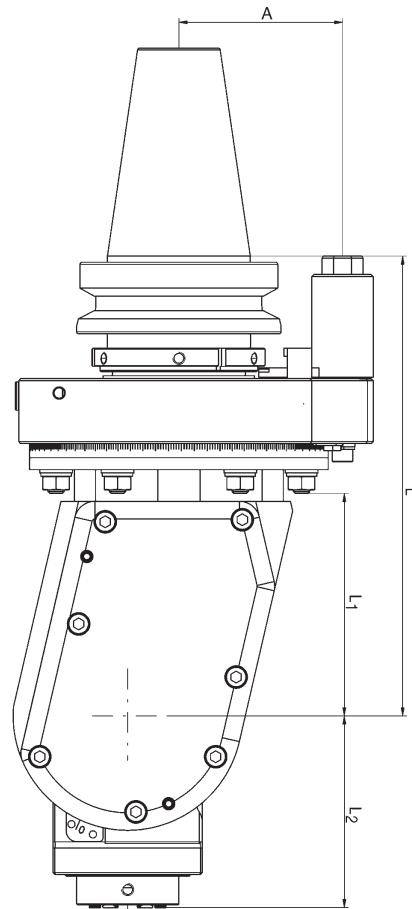
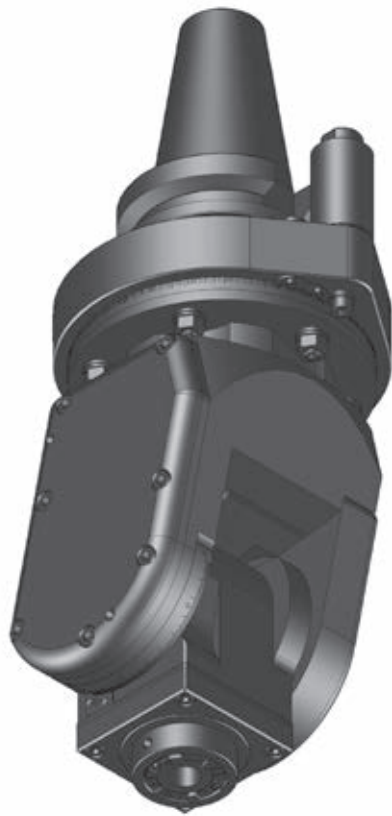

Size	Torque max.	Rev. max. (r.p.m.)	Gear Ratio	L mm	L1 mm	H mm	A mm	kg	SW
5	30 Nm	7.000 / 13.500	i = 1:1 / 1:2,25	205	100	111	80	14,0	18
7	70 Nm	6.000	i = 1:1	225	109	132	80	16,0	18

Size	Toolholder	L2 mm	L4 mm	Order No. (i=1:1)		Order No. (i=1:2,25)	
				without coolant	internal coolant	without coolant	internal coolant
5	ER 25	84	25	162970	105830	162972	162971
5	mi 40	97	25	162973	169979	162975	162974
7	ER 32	95	25	162985	105859		
7	mi 50	108	25	162988	167553		

ANSI CAT 40 WS

Angle Head, Adjustable 0-98°

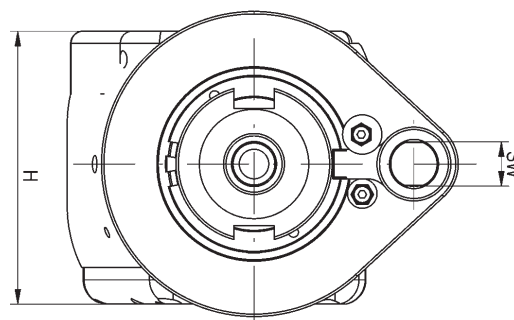
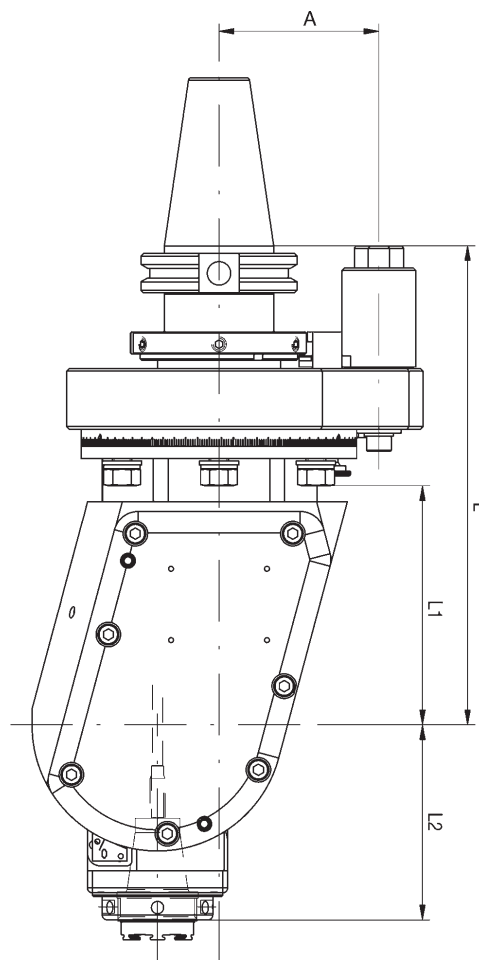
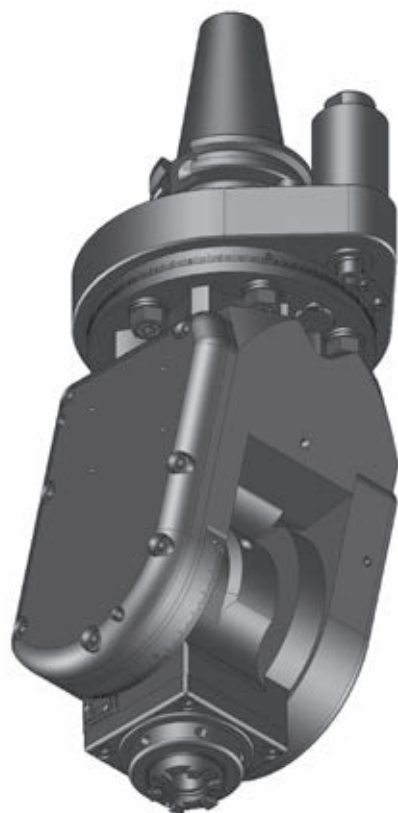
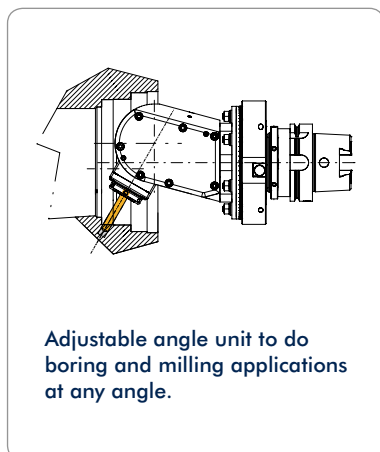

Size	Torque max.	Rev. max. (r.p.m.)	Gear Ratio	L mm	L1 mm	H mm	A mm	kg	SW
3	15 Nm	8.000 / 15.000	i = 1:1 / 1:2,25	189	91	96	65	8,0	18
5	30 Nm	7.000 / 13.500	i = 1:1 / 1:2,25	195	96	111	65	9,6	18

Size	Toolholder	L2 mm	L4 mm	Order No. (i=1:1)		Order No. (i=1:2,25)	
				without coolant	internal coolant	without coolant	internal coolant
3	ER 20	75,0	20	162797	135811	162800	162801
3	mi 32	82,9	20	156566	167896	156567	156568
5	ER 25	84,0	25	172227	135838	162717	135781
5	mi 40	97,0	25	162932	135817	162725	162724

ANSI CAT 50 WS

Angle Head, Adjustable 0-98°

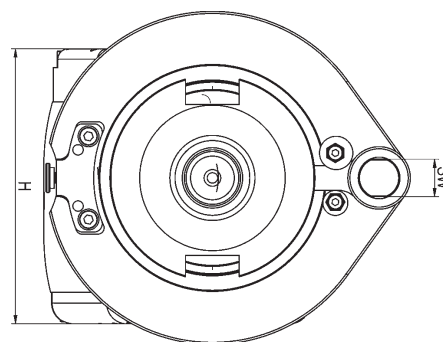
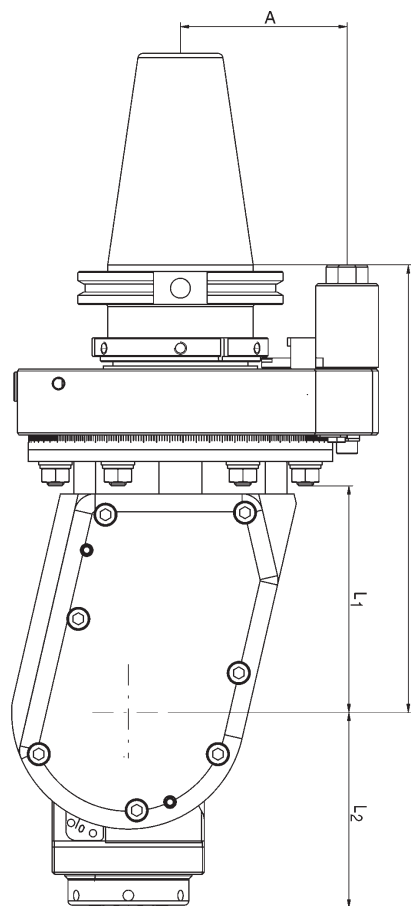
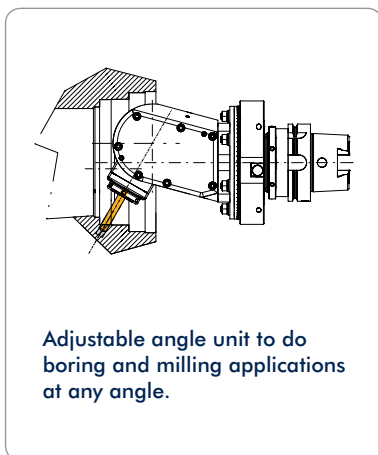

Size	Torque max.	Rev. max. (r.p.m.)	Gear Ratio	L mm	L1 mm	H mm	A mm	kg	SW
5	30 Nm	7.000 / 13.500	i = 1:1 / 1:2,25	195	100	111	80	14,0	18
7	70 Nm	6.000	i = 1:1	215	109	132	80	16,0	18

Size	Toolholder	L2 mm	L4 mm	Order No. (i=1:1)		Order No. (i=1:2,25)	
				without coolant	internal coolant	without coolant	internal coolant
5	ER 25	84	25	162946	135839	162947	162948
5	mi 40	97	25	162951	169978	162950	162949
7	ER 32	95	25	162984	162983		
7	mi 50	108	25	162990	169941		

Checklist for Inquiry

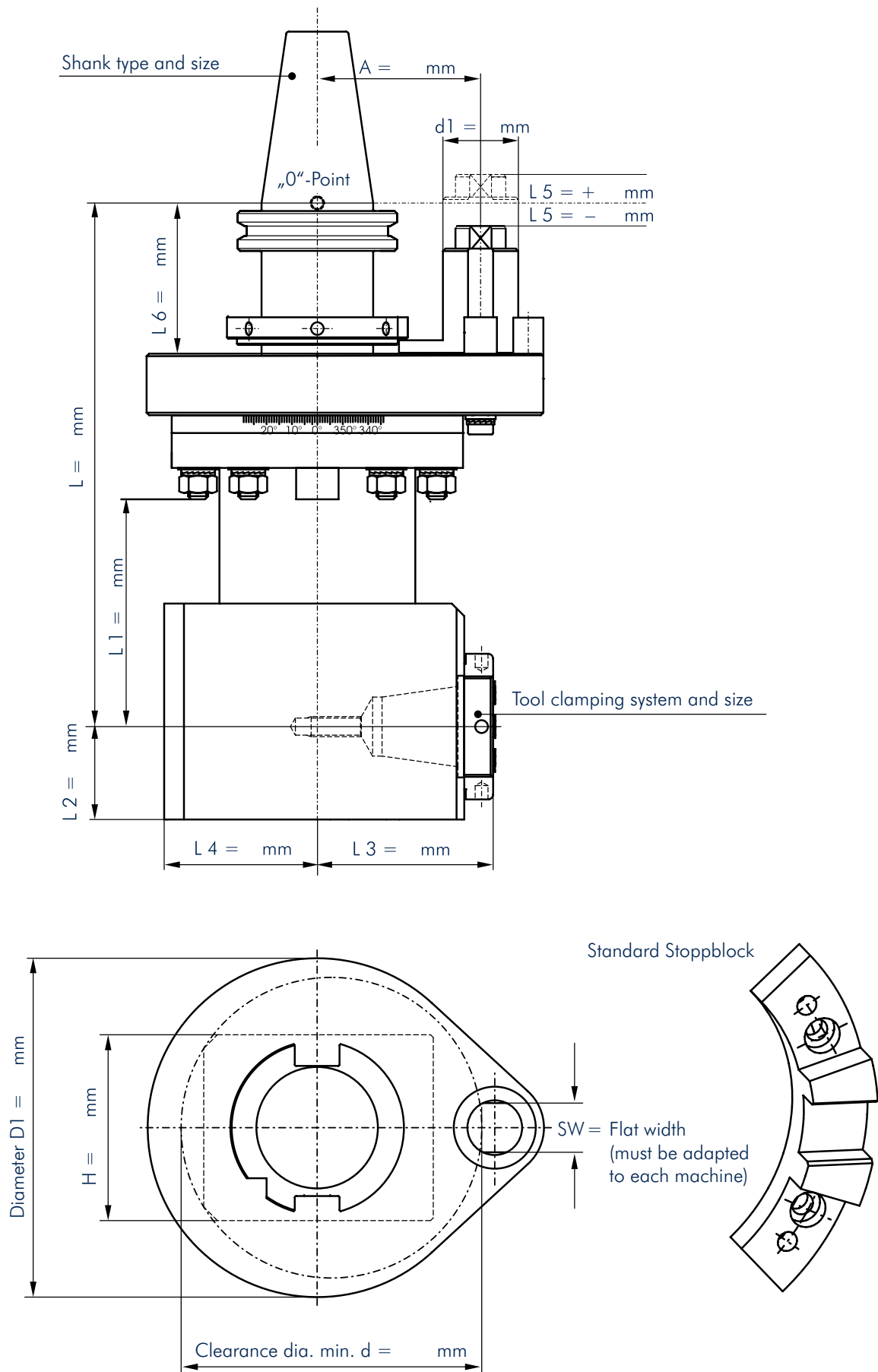

**Modular Quick Change
Systems mi and Hydroflex**

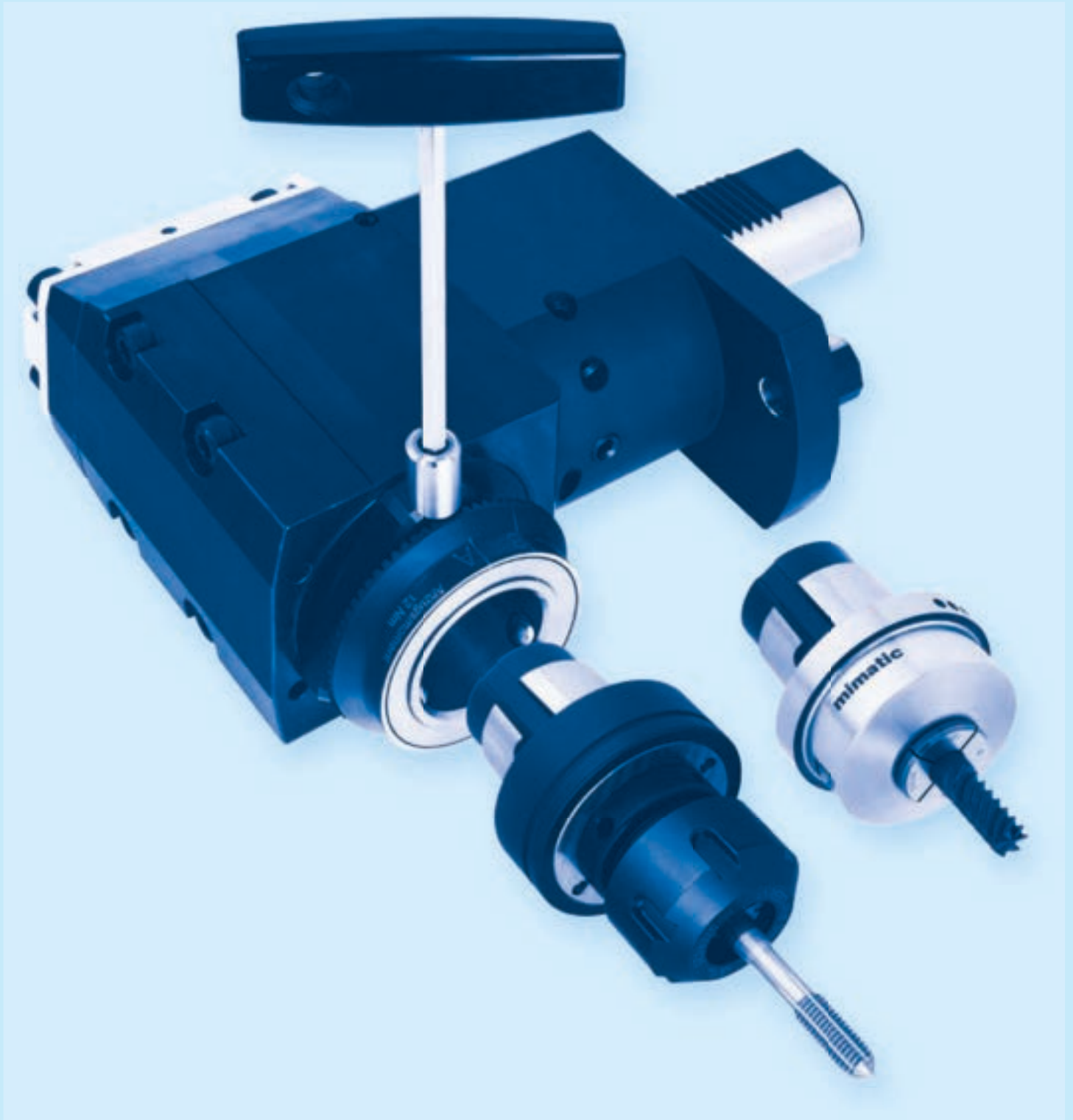

Table of Contents

	Size	Standard	Page
Basic Toolholders 	SK 40/50	DIN 69871	472
	BT 40/50	MAS-BT	472
	HSK 63	DIN 69893	472
Collet Chucks 	ER 11 - ER 40	DIN 6499	473
Combination Shell End Mill Arbors 	Ø 16-27 mm		473
Weldon Toolholders Whistle-Notch Toolholders 	Ø 6-25 mm Ø 1/4"-1/0"	DIN 1835 B DIN 1835 B	474 474
Synax® Tapping Quick Change Holders 	Ø 3,5-16 mm		475
Softsynchro Chucks (Licence Emuge) 	M4-M12		475
Hydraulic Chucks 	Ø 12 + 20 mm		473
	Accessories		476
Shrink fit Chucks 	Ø 8-20 mm		477
	Accessories		477
Accessories 	Blank		477
	Test Mandrel		477
	Tool-presetting unit		478
	Wrench		479
	Assembling jig		479
	Protection plug		479
Hydroflex 	Ø 20-25 mm		482

mimaticMi

Advantages

- Universal tool clamping system for all production areas
- Presetting of the tools off-line by length adjustment screw
- Tool change within seconds
- Concentricity of the interface < 0,002 mm
- Secure holding force by form-locking
- Very short design
- Toolholders in different sizes
- All toolholders with internal coolant

Use on CNC-Turning Machines and Machining Centers

Driven toolholders for all turning machines, machining centers, milling machines, turn/mill centers as well as transfer and special machines. Driven toolholders / basic holders are available in many different versions:

- Shafts such as VDI, SK, BT, CAT, HSK, Capto, ...
- Straight and angle units
- Single or multi-spindle versions
- Gear multiplication or reduction
- Internal and/or external coolant supply
- Central or offset

Modular Toolholders in Different Sizes for All Production Areas

- Tapping toolholders
- Collet toolholders (internal and external nut)
- Hydro-Flex hydraulic toolholders
- Thread tightening toolholder cutters
- Morse taper shank toolholders
- Weldon and Whistle Notch toolholders
- Shell mill toolholders

All toolholders are available for use with your presetter.

mi Operation

- Insert the toolholder into the spindle of the driven toolholder
- 3 balls inside the modular mimatic mi interface guide the toolholder into the proper position
- Turn the toolholder until it is locked
- Clamping the sleeve nut by using the mimatic one hand key
- To unclamp the toolholder just follow all steps in reverse order
- The axial and conical surface guarantee highest concentricity
- All toolholders are with internal coolant and available in different sizes

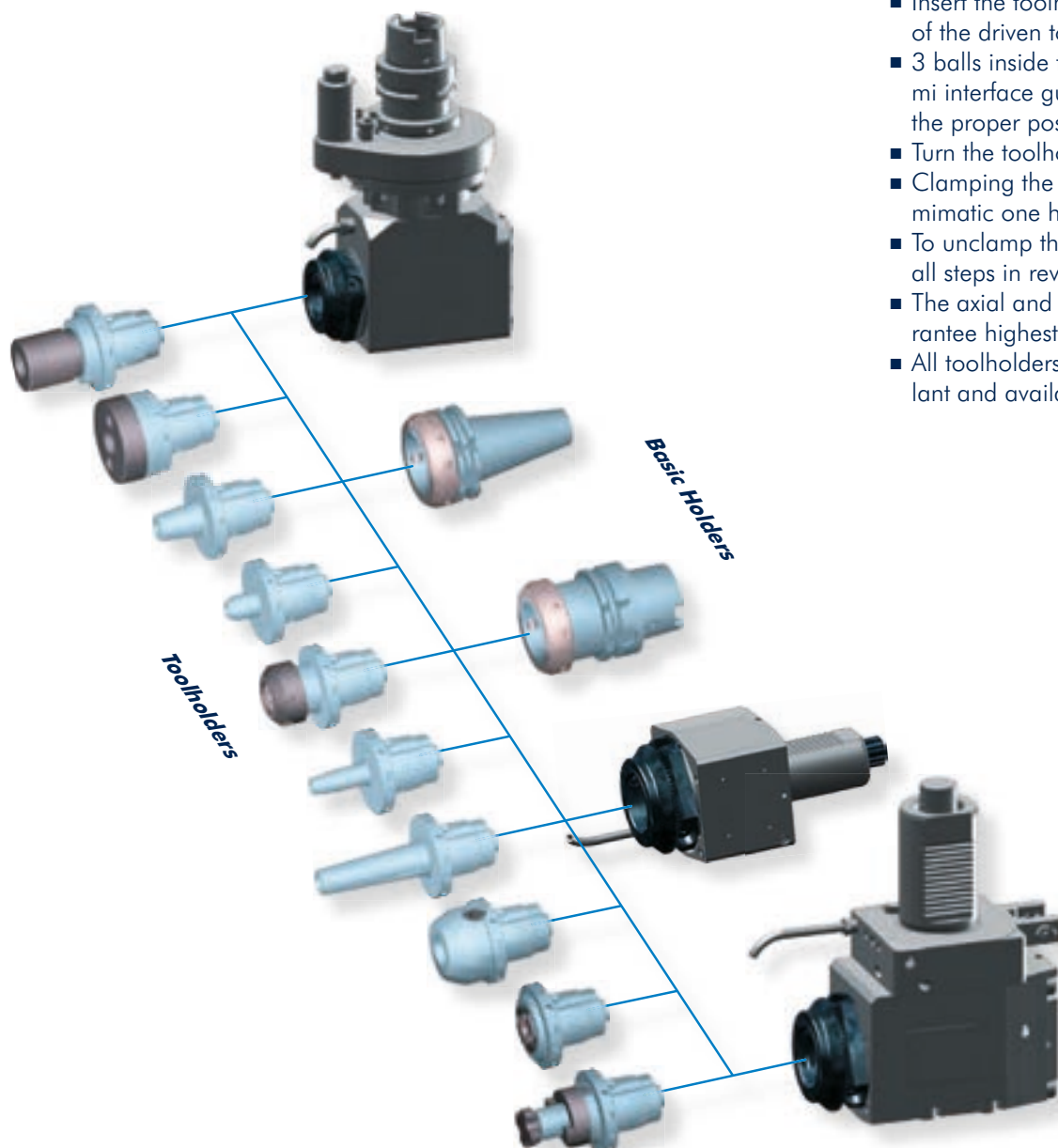

Basic Holders

DIN 69871 AD/B

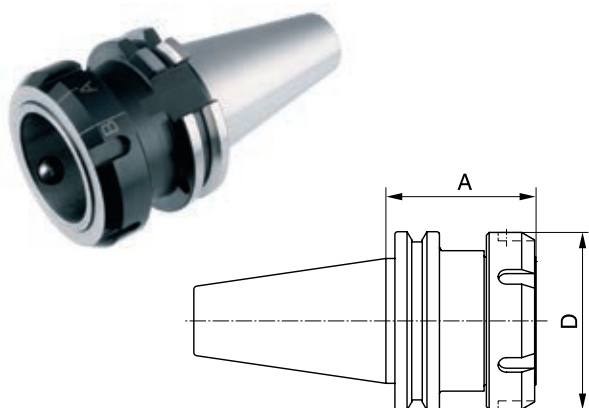

Order No.	Size	SK	A mm	D mm
121454	mi 32	SK 30	53,5	45
155404	mi 40	SK 40	53,5	54
155502	mi 50	SK 40	53,5	63
155481	mi 50	SK 50	53,5	63
155477	mi 63	SK 50	58,5	77

MAS-BT JIS 6339

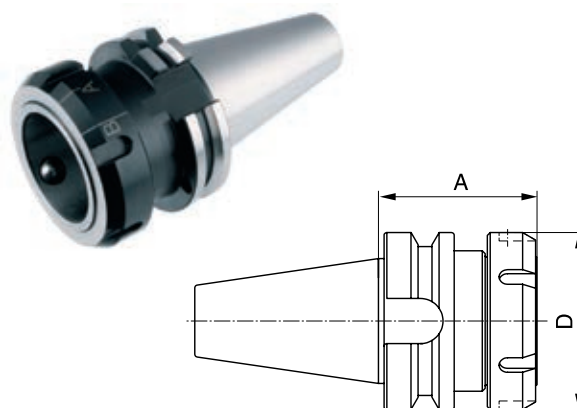

Order No.	Size	BT	A mm	D mm
121481	mi 32	BT 30	45,0	45
121512	mi 40	BT 40	48,5	54
155469	mi 50	BT 40	56,5	63
155457	mi 50	BT 50	61,5	63
121552	mi 63	BT 50	70,0	77

DIN 69893 A

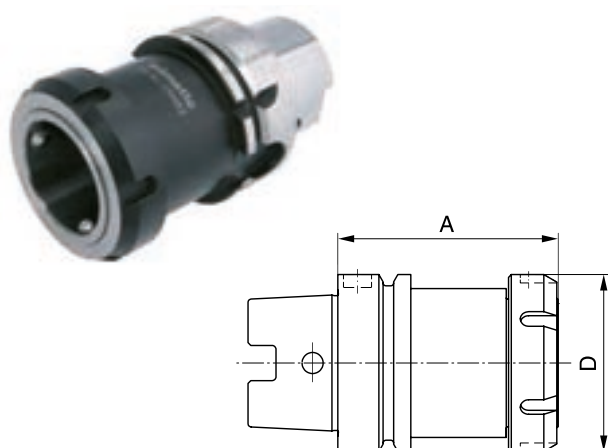

Order No.	Size	HSK	A mm	D mm
155410	mi 40	HSK 50	60,0	54
155458	mi 50	HSK 63	78,5	63
121562	mi 50	HSK 100	85,0	63
121577	mi 63	HSK 100	100,0	77

Cylindrical shank with clamping surface

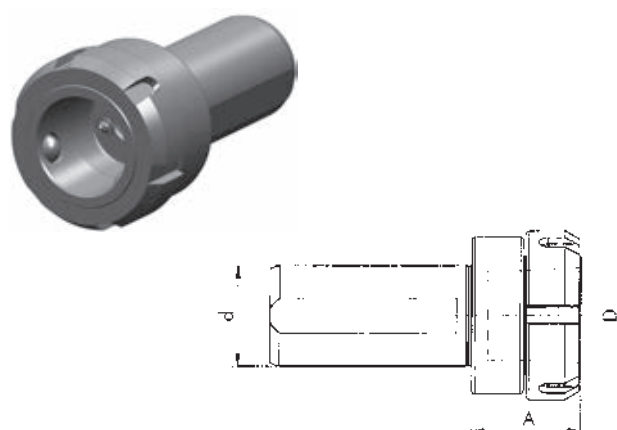

Order No.	Size	Ø d mm	A mm	D mm
180538	mi 40	32	35	54

Collet Chucks DIN 6499 – Type ER

- short type
- clamping nut inside
- with internal coolant

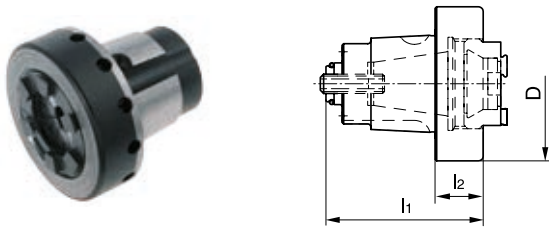

- long type
- clamping nut outside
- with internal coolant

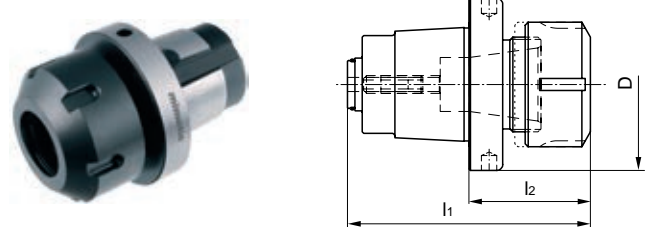

Order No.	Size	Collet	l1 mm	l2 mm	D mm
121479	mi 32	ER 11	41,5	15	42
155357	mi 32	ER 16	41,5	15	42
171839	mi 32	ER 20	59,0	32	36
155388	mi 40	ER 16	45,0	11	48
155335	mi 40	ER 20	49,0	15	48
155367	mi 40	ER 25	55,0	21	48
155418	mi 50	ER 25	55,0	14	58
155460	mi 50	ER 32	59,0	18	58
155471	mi 63	ER 32	63,0	14	75
155496	mi 63	ER 40	69,0	20	75

Order No.	Size	Collet	l1 mm	l2 mm	D mm
155358	mi 32	ER 11	72,5	46,0	42
155319	mi 32	ER 16	64,5	38,0	42
121460	mi 40	ER 16	73,0	39,0	48
121502	mi 40	ER 20	80,0	46,6	48
155448	mi 50	ER 25	82,0	41,0	58
155445	mi 50	ER 32	88,0	47,0	58
155475	mi 63	ER 32	96,0	47,0	75
155451	mi 63	ER 40	94,5	45,5	75

Combination Shell End Mill Arbor

without internal coolant

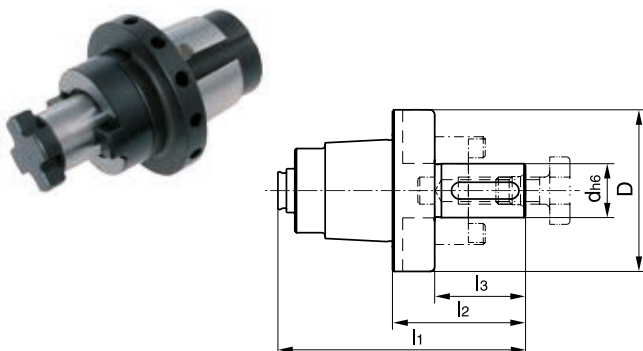

Order No.	Size	l1 mm	l2 mm	l3 mm	d h6 mm	D mm
121486	mi 32	66,0	39,5	27	16	42
155365	mi 40	73,5	39,5	25	16	48
155447	mi 50	82,0	41,0	27	16	58
155413	mi 50	88,0	47,0	31	22	58
155512	mi 63	96,0	47,0	31	22	75
155465	mi 63	98,0	49,0	33	27	75

Hydraulic Chuck

with internal coolant

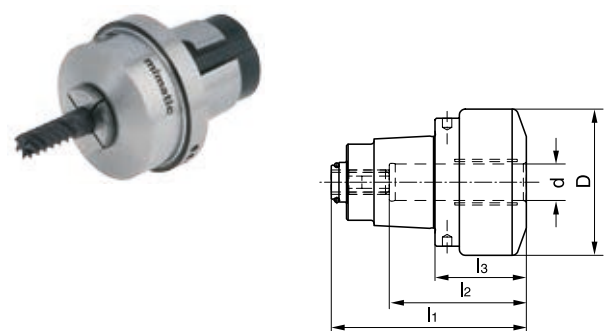

Order No.	Size	l1 mm	l2 mm	l3 mm	d h6 mm	D mm
155391	mi 40	64	45	30	12	48
155417	mi 50	71	52	30	20	58

Weldon Toolholder DIN 1835 B

with internal coolant

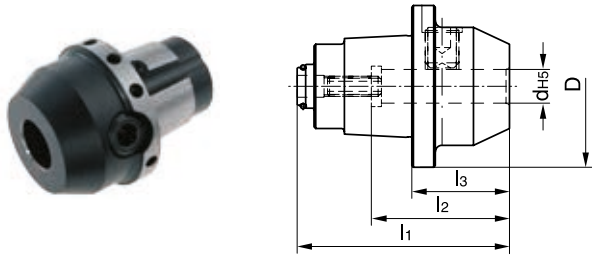

Order No.	Size	l1 mm	l2 mm	l3 mm	d H5 mm / "	D mm
121436	mi 32	52,5	37	26,0	6	42
121478	mi 32	52,5	37	26,0	8	42
121469	mi 32	55,5	41	29,0	10	42
121439	mi 32	57,5	46	31,0	12	42
121449	mi 32	52,5	37	26,0	1/4"	42
121472	mi 32	55,5	41	29,0	3/8"	42
121448	mi 32	57,5	46	31,0	1/2"	42
155330	mi 40	60,0	37	26,0	6	48
155346	mi 40	60,0	37	26,0	8	48
155321	mi 40	63,0	41	29,0	10	48
155331	mi 40	65,0	46	31,0	12	48
155326	mi 40	65,0	46	31,0	14	48
155379	mi 40	68,0	49	34,0	16	48
121497	mi 40	60,0	37	26,0	1/4"	48
121475	mi 40	63,0	41	29,0	3/8"	48
121474	mi 40	65,0	46	31,0	1/2"	48
121499	mi 40	68,0	49	34,0	5/8"	48
155419	mi 50	65,0	37	24,0	6	58
155411	mi 50	66,0	37	25,0	8	58
155400	mi 50	70,0	41	29,0	10	58
155406	mi 50	73,0	46	32,0	12	58
155412	mi 50	73,0	46	32,0	14	58
155407	mi 50	74,0	49	33,0	16	58
155427	mi 50	78,0	51	37,0	20	58
121489	mi 50	65,0	37	24,0	1/4"	58
121529	mi 50	40,0	41	29,0	3/8"	58
121525	mi 50	73,0	46	32,0	1/2"	58
121520	mi 50	75,0	49	34,0	5/8"	58
121526	mi 50	78,0	51	37,0	3/4"	58
155470	mi 63	81,0	37	32,0	6	75
155459	mi 63	82,0	37	33,0	8	75
155490	mi 63	85,0	41	36,0	10	75
155509	mi 63	88,5	46	39,5	12	75
155463	mi 63	88,5	46	39,5	14	75
155482	mi 63	91,0	49	42,0	16	75
155474	mi 63	93,0	51	44,0	20	75
155464	mi 63	110	59	61,0	25	75
166815	mi 63	81,0	37	32,0	1/4"	75
166805	mi 63	85,0	41	36,0	3/8"	75
166813	mi 63	88,5	46	39,5	1/2"	75
166807	mi 63	91,0	49	42,0	5/8"	75
166804	mi 63	93,0	51	44,0	3/4"	75
166812	mi 63	110	59	61,0	1/0"	75

Whistle Notch Toolholder DIN 1835 E

with internal coolant

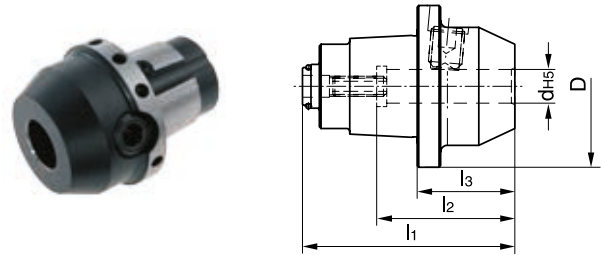

Order No.	Size	l1 mm	l2 mm	l3 mm	d H5 mm / "	D mm
121463	mi 32	52,5	36	26,0	6	42
121464	mi 32	52,5	36	26,0	8	42
121443	mi 32	55,5	40	29,0	10	42
121453	mi 32	57,5	45	31,0	12	42
121442	mi 32	52,5	36	26,0	1/4"	42
121485	mi 32	55,5	40	29,0	3/8"	42
121480	mi 32	57,5	45	31,0	1/2"	42
155369	mi 40	60,0	36	26,0	6	48
155363	mi 40	60,0	36	26,0	8	48
155370	mi 40	63,0	40	29,0	10	48
155364	mi 40	65,0	45	31,0	12	48
155333	mi 40	65,0	45	31,0	14	48
155382	mi 40	68,0	48	34,0	16	48
121492	mi 40	60,0	36	26,0	1/4"	48
121493	mi 40	63,0	40	29,0	3/8"	48
121455	mi 40	65,0	45	31,0	1/2"	48
121494	mi 40	68,0	48	34,0	5/8"	48
169197	mi 40	89,0	50	55,0	20	52
155416	mi 50	65,0	36	24,0	6	58
155401	mi 50	66,0	36	25,0	8	58
155383	mi 50	70,0	40	29,0	10	58
155408	mi 50	73,0	45	32,0	12	58
155435	mi 50	73,0	45	32,0	14	58
155436	mi 50	75,5	48	34,5	16	58
155384	mi 50	78,0	50	37,0	20	58
166816	mi 50	65,0	36	24,0	1/4"	58
155440	mi 50	70,0	40	29,0	3/8"	58
155434	mi 50	73,0	45	32,0	1/2"	58
155428	mi 50	75,0	48	34,0	5/8"	58
155385	mi 50	78,0	50	37,0	3/4"	58
166104	mi 63	81,0	36	32,0	6	75
166105	mi 63	82,0	36	33,0	8	75
166110	mi 63	85,0	40	36,0	10	75
166112	mi 63	88,5	45	39,5	12	75
166113	mi 63	88,5	45	39,5	14	75
166114	mi 63	91,0	48	42,0	16	75
166115	mi 63	93,0	50	44,0	20	75
166116	mi 63	110	56	61,0	25	75
166797	mi 63	81,0	36	32,0	1/4"	75
166799	mi 63	85,0	40	36,0	3/8"	75
166796	mi 63	88,5	45	39,5	1/2"	75
166803	mi 63	91,0	48	42,0	5/8"	75
166798	mi 63	93,0	50	44,0	3/4"	75
166795	mi 63	110	56	61,0	1/0"	75

SYNAX® Tapping Quick Change Holder

without internal coolant,
with synchronisation and length compensation

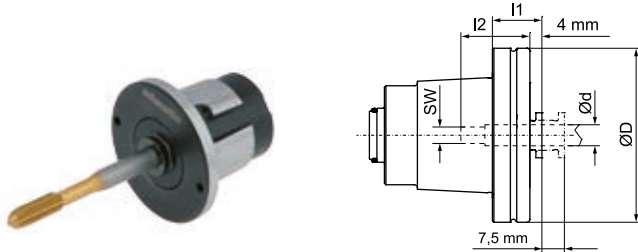

Order No.	Size	l1 mm	l2 mm	d mm	D mm	SW
121510	mi 40	17,0	25	3,5	48	2,7
155397	mi 40	17,0	25	4,5	48	3,4
155377	mi 40	17,0	27	6,0	48	4,9
155378	mi 40	17,0	27	8,0	48	6,2
155403	mi 40	38,0	28	9,0	48	7,0
121451	mi 40	38,0	29	10,0	48	8,0
121498	mi 40	38,0	30	12,0	48	9,0
155450	mi 50	16,5	25	3,5	58	2,7
155487	mi 50	16,5	25	4,5	58	3,4
155422	mi 50	16,5	27	6,0	58	4,9
155497	mi 50	16,5	27	7,0	58	5,5
155455	mi 50	16,5	27	8,0	58	6,2
155423	mi 50	16,5	28	9,0	58	7,0
155466	mi 50	16,5	29	10,0	58	8,0
155472	mi 50	44,0	36	11,0	58	9,0
155449	mi 50	16,5	30	12,0	58	9,0
155479	mi 50	44,0	33	16,0	58	12,0

with internal coolant (70 bar),
only synchronisation

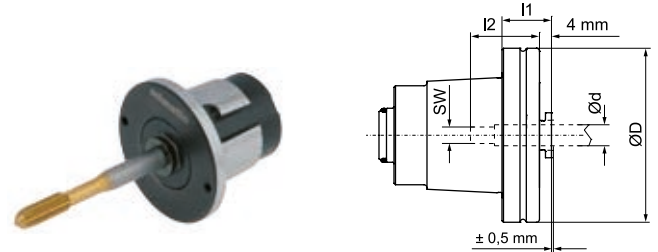

Order No.	Size	l1 mm	l2 mm	d mm	D mm	SW
155389	mi 40	17,0	27	6	48	4,9
121522	mi 40	17,0	27	8	48	6,2
121515	mi 40	38,0	28	9	48	7,0
121504	mi 40	38,0	29	10	48	8,0
121517	mi 40	38,0	30	12	48	9,0
155432	mi 50	16,5	27	6	58	4,9
172720	mi 50	16,5	27	7	58	5,5
155498	mi 50	16,5	27	8	58	6,2
155473	mi 50	16,5	28	9	58	7,0
155467	mi 50	16,5	29	10	58	8,0
155446	mi 50	16,5	30	12	58	9,0
121534	mi 50	44,0	33	16	58	12,0

Softsynchro Chuck (Licence Emuge)

with internal coolant,
with push and pull length
compensation 0,5 mm

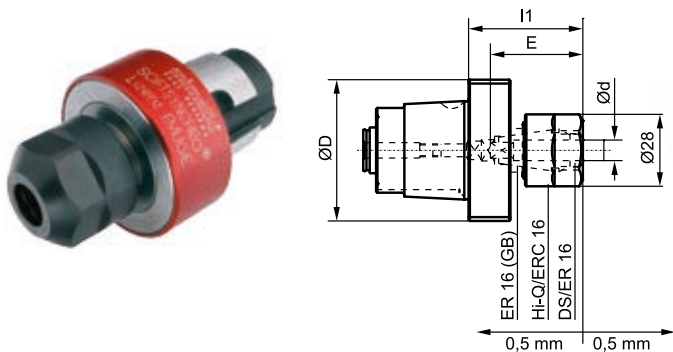

Order No.	Size	Collet	Thread	l1 mm	d mm	D mm
121503	mi 40	ER-GB 16	M4-M12	47,5	4,5-10	45
121530	mi 50	ER-GB 16	M4-M12	44,5	4,5-10	50

Chuck for GB Collets

with internal coolant,
with push and pull length
compensation ±0,5 mm

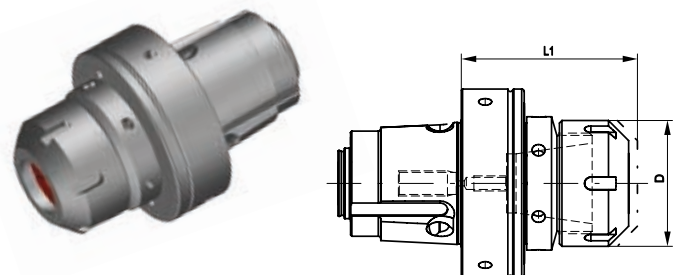

Order No.	Size	Collet	L1 mm	D mm
121518	mi 40	ER 20 GB(1-13)	60	28
155488	mi 50	ER 25 GB(1-16)	60	42
155491	mi 63	ER 32 GB(2-20)	70	50

Accessory for Hydraulic Chucks

Sleeve

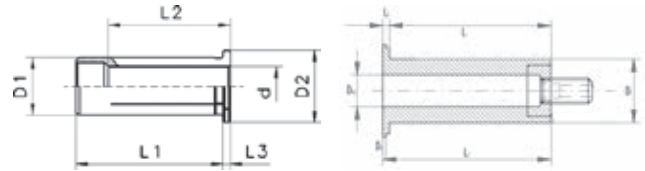

without horizontal adjustment

with horizontal adjustment

Order No.	D1 mm	d h6 mm / "	L1 mm	L2 mm	L3 mm	D2 mm
119790	12	3	40	29	4	16
119793	12	1/8"	40	29	4	16
119797	12	4	40	29	4	16
119798	12	3/16"	40	29	4	16
119819	12	5	40	29	4	16
119812	12	6	40	36	4	16
119813	12	1/4"	40	36	4	16
119791	12	7	40	37	4	16
119799	12	5/16"	40	37	4	16
119810	12	8	40	37	4	16
119792	12	9	40	37	4	16
119815	12	3/8"	40	40	4	16
119814	12	10	40	40	4	16
119816	20	3	50	28	4	25
119823	20	1/8"	50	28	4	25
119817	20	4	50	28	4	25
119837	20	3/16"	50	28	4	25
119800	20	5	50	28	4	25
119801	20	6	50	36	4	25
119822	20	1/4"	50	36	4	25
119818	20	7	50	38	4	25
119839	20	5/16"	50	37	4	25
119820	20	8	50	37	4	25
119802	20	9	50	38	4	25
119838	20	3/8"	50	38	4	25
119824	20	10	50	40	4	25
119825	20	11	50	40	4	25
119830	20	7/16"	50	45	4	25
119826	20	12	50	45	4	25
119821	20	1/2"	50	45	4	25
119827	20	14	50	45	4	25
119846	20	9/16"	50	45	4	25
119829	20	5/8"	50	48	4	25
119828	20	16	50	48	4	25
119847	25	3	56	29	4	30
119848	25	4	56	29	4	30
119831	25	5	56	29	4	30
119849	25	6	56	37	4	30
119832	25	7	56	37	4	30
119833	25	8	56	37	4	30
119834	25	9	56	38	4	30
119850	25	10	56	40	4	30
119835	25	12	56	46	4	30
119851	25	14	56	47	4	30
119836	25	16	56	48	4	30
119841	25	18	56	48	4	30
119842	25	20	56	50	4	30
119844	32	6	60	36	4	36

Order No.	D1 mm	d h6 mm / "	L1 mm	L2 mm	L3 mm	D2 mm
119857	32	1/4"	60	36	4	36
119845	32	7	60	37	4	36
119879	32	5/16"	60	36	4	36
119852	32	8	60	36	4	36
119855	32	9	60	37	4	36
119884	32	3/8"	60	37	4	36
119864	32	10	60	40	4	36
119853	32	11	60	40	4	36
119858	32	12	60	45	4	36
119856	32	1/2"	60	45	4	36
119859	32	13/16"	60	45	4	36
119865	32	14	60	46	4	36
119854	32	15/16"	60	46	4	36
119861	32	5/8"	60	46	4	36
119866	32	16	60	48	4	36
119870	32	18	60	49	4	36
119878	32	3/4"	60	50	4	36
119877	32	20	60	50	4	36
119867	32	25	60	56	4	36

with horizontal adjustment

119909	20	6	50	52	-	28
119889	20	8	50	52	-	28
152696	20	10	50	52	-	28
119910	20	12	50	52	-	28
119901	20	14	50	52	-	28
119911	20	16	50	52	-	28
119892	20	18	50	52	-	28
119893	25	10	56	59	-	32
119912	25	12	56	59	-	32
119894	25	14	56	59	-	32
119895	25	16	56	59	-	32
167144	25	18	56	59	-	32
167045	25	20	56	59	-	32

Shrink fit Chuck

with internal coolant

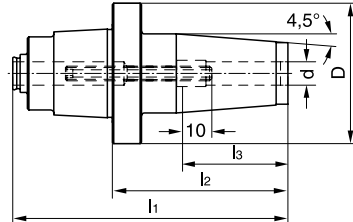

Order No.	Size	l1 mm	l2 mm	l3 mm	d h6 mm	D mm
155381	mi 40	94	60	36	8	48
121482	mi 40	94	60	42	10	48
155334	mi 40	99	65	47	12	48
121501	mi 40	104	70	50	16	48
155421	mi 50	101	60	36	8	58
155409	mi 50	101	60	42	10	58
155444	mi 50	106	65	47	12	58
155438	mi 50	106	65	47	14	58
155430	mi 50	111	70	50	16	58
155431	mi 50	116	75	50	18	58
155454	mi 50	116	75	52	20	58

Accessory for Shrink fit Chucks

Sleeve

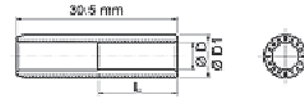

Order No.	L mm	L1 mm	d h6 mm	D mm
119807	30,5	7,5	2,5	8
119787	30,5	9,0	3,0	8
119808	30,5	10,5	3,5	8
119809	30,5	12,0	4,0	8
119788	30,5	13,5	4,5	8
119789	30,5	15,0	5,0	8
119796	30,5	16,5	5,5	8

Blank

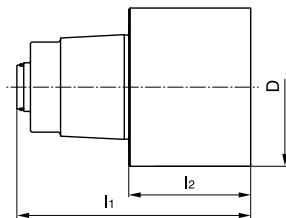

Order No.	Size	l1 mm	l2 mm	D mm
121457	mi 32	76,5	50	42
166791	mi 40	94,0	60	48
166789	mi 50	111,0	70	58
121557	mi 63	129,0	80	75

Test Mandrel

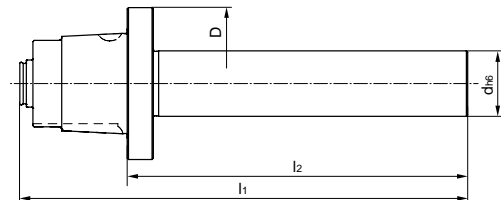

Order No.	Size	l1 mm	l2 mm	d h6 mm	D mm
170569	mi 25		110		14
172991	mi 32		110		18
156208	mi 40		130		20
156082	mi 50		130		25
172992	mi 63		150		32

Tool Presetting Unit

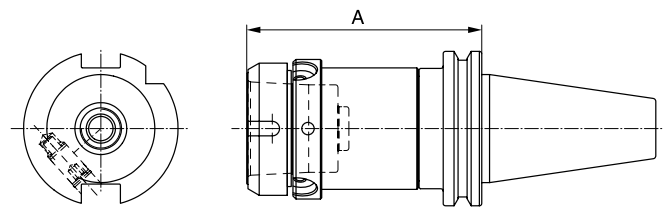
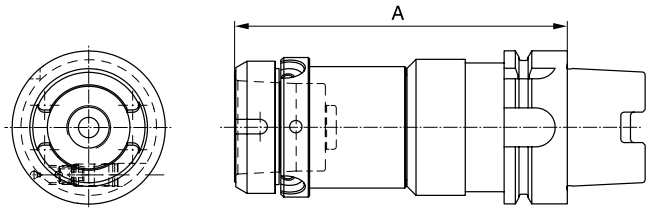

Order No.	Size	HSK	A mm
171098	mi 25	63	130,0
155352	mi 32	63	130,0
155380	mi 40	63	134,5
173224	mi 40	100	143,0
155429	mi 50	63	136,9
168301	mi 50	100	143,0
166990	mi 63	63	147,0
169267	mi 63	100	155,0

Order No.	Size	SK	A mm
121471	mi 40	40	95
121491	mi 40	50	128
155405	mi 50	40	97
121527	mi 50	50	140
155504	mi 63	50	140

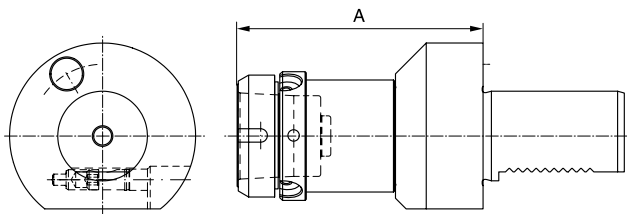

Order No.	Size	VDI	A mm
155368	mi 40	40	108
155356	mi 50	40	110
155372	mi 40	50	108
121524	mi 50	50	110

Accessories for mi-system

Complete Wrench for One-hand Operation



Order No.	Size
170734	mi 25, mi 32, mi 40
170419	mi 50, mi 63

Torque Wrench for Gearing



Order No.	Size
180356	mi 50, mi 63

Socket Wrench for Torque Wrench



Order No.	Size	L mm	Wrench size
173988	mi 25, mi 32, mi 40	50	1/4"
173985	mi 50, mi 63	50	1/4"

Assembling Jig

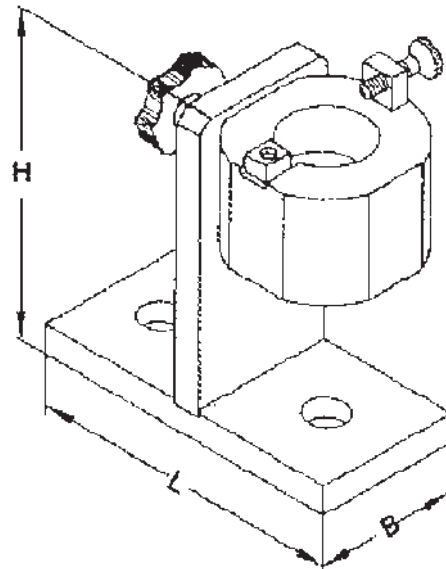

Protection Plug

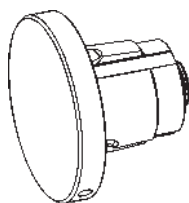

Order No.	Size
174460	mi 32
174458	mi 40
174457	mi 50
174459	mi 63

Order No.	Size	L mm	B mm	H mm
166774	SK 40	130	64	136
166775	HSK 63	130	64	136
121571	VDI 40	130	64	136

mimatic mi – An Epitome of BlueCompetence

BLUECOMPETENCE

Alliance Member

Partner of the Engineering Industry Sustainability Initiative

mimatic® Tool Systems for Sustainability and Efficiency

Tools according to the policy of BLUECOMPETENCE are marked in this catalogue. More information on the program (Initiative) of the VDMA see pages 16-17.

mi – The Integrated Tool Solution = Live Tool + mi Interface + mi Tool



Advantages

mi – Interface, Driven Tool Sided

- short taper + planar arrangement
- shorter construction
- convenient single-hand operation
- symmetrical 3-point intake

mi – Fast Change

- in the machine
- minimal tool changing time
- no pre-adjustment necessary

mi – Chipping Tool

- compact – one-piece design
- milling, counterboring, planing, chamfering
- shells, shaft, ...

BlueCompetence – Implemented with mimatic mi

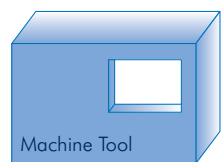

Old = Industrial Standard

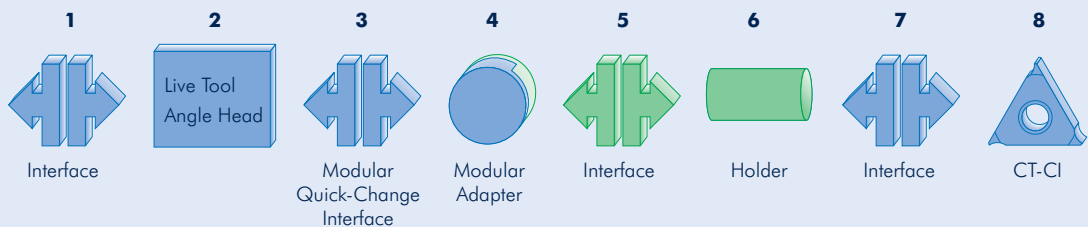

New = mimatic Innovation

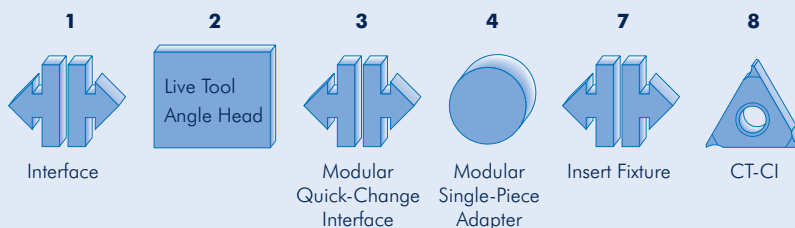
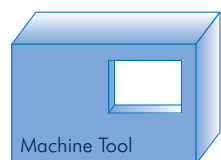

mi System Solutions for Special Production Assignments

Live Tools with mi quick-change interface must be adapted to the machining task in your dimensioning, and/or take this task into account:

- as regards the cutting forces and/or torque occurring and
- as regards the precision required » rigidity of the system

It is thus necessary to describe the planned machining processes as exactly as possible, so that the optimal technical and economic suggestion can be worked out. Because then it is ensured that the requirements for precision, efficiency and sustainability are fulfilled.

Live Tools - mi
Straight Unit



Live Tools - mi
Angle Unit



mi - Milling Tool

- 5 different CT plates
 - chamfering
 - milling threads
 - milling planes
 - counterboring
- Material: AlMgSi1 (DIN 3.2315)

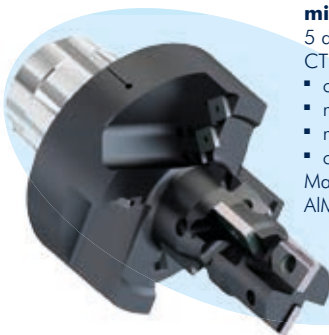

mi - Cutting Tool

- jiggering
 - chamfering
- Materials:
1. 20MnVS6
2. X15 CrNiSi20 (DIN 1.4828)



mi - Cutting Tool

- twist drill
 - jiggering
 - planing
- Material: Al-Si7Mg



mi - Cutting Tool

- drilling
- planing
- VHM twist drill
- chamfering



mi - Milling Tool

- groove milling
- Material: steel



mi - Milling Tool

- groove milling
- Material: steel



mi - Milling Tool

- contour milling
- Material: 16MnCrS5



mi - Counterboring Tool

- (jiggering)
 - preturning
 - finish-turning
 - planing
 - chamfering
- Material: Al-Si7Mg



mi - Milling Tool

- groove milling
- Material: steel



mi - Milling Tool

- groove milling
- Material: steel



HydroFLEX

Vibration reduced tool clamping system for all applications
(reaming, drilling, milling, tapping, ...)

- Concentricity < 0,002 mm
- Holding forces up to 290 Nm
- Usability in our mimatic® driven toolholders



Hydroflex Expansion
Clamping Sleeve D20

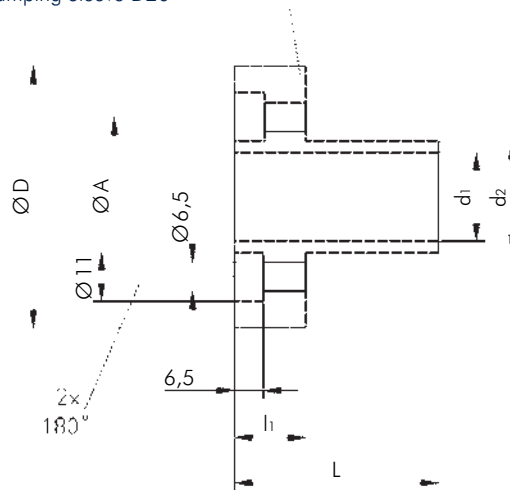
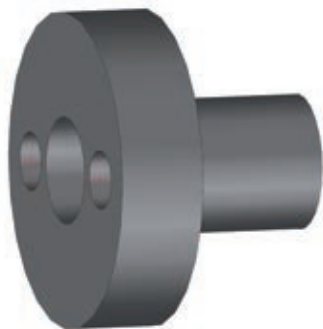

Sleeves see page 516

Order No.	d1 mm	d2 mm	D	L	l1	A	for clamping bolt DIN 6912
113056	20	25	59	46	16	36	M6 x16
113134	25	32	67	50	16	44	M6 x16

Useful facts about vibrations of boring bars

The result of vibrations many times is a bad surface and wear of the cutting edges ending as a negative production output. The origin of vibrations could be caused by:

- If the boring bar is clamped in a worn-out holder, the result could be that the angle of cut from the boring bar is not correct
- Not enough machine stability
- Flat cutting angle
- High cutting pressure forced by a high feed

Advantages of the modular hydraulic clamping system

- Same characteristics as „Hydraulic spindles“ – but with less expense!
- Concentricity < 0.002 mm
- Transferable torque > 80 Nm – with 12.000 RPM capabilities
- Unique tool holding system absorbs vibrations during machining: drilling, milling, reaming, threading
- Longer tool-live and a 60% longer tool length is possible
- No concentricity errors regarding the interface
- Tool pre-setting out of the machine is achievable using length adjustable reducing sleeves – Gives you more UP time!
- Reducing sleeves available from 6-20 mm
- Tool live improvement up to 100 %
- Extremely stable and rigid design
- Retention of hydraulic clamping sleeves as high as 290 Nm
- Concentricity is consistent through-out the interface range, unlike many competitive systems
- Tap sleeves are also available

Exchange of Hydro-Flex sleeve

- Unclamp both axial screws
- Remove the Hydro-Flex in unclamped condition
- Never clamp the spindle outside and/or without a tool!
- Only clamp the sleeve together with tools of cylindrical shank – no Weldon or Whistle Notch!

Tool pre-setting

Outside of the CNC turning machine or CNC machining center you can preset your cutting tool with the sleeve. With the reduction sleeve you can use a stop (external: M16 x 1,5 / internal: M8) (M8 / L = 16 mm).

With the reduction sleeve you can use a stop (external: M16 x 1,5 / internal: M8) (M8 / L = 16 mm).

Reduction sleeve sizes:

L = 52 mm, l = 37 mm, D = 20 mm
d = 6, 7, 8, 10, 12, 14, 16, 18 mm

Tapping sleeve sizes:

Clamping sleeves d = 10, 12 , 16 mm (D = 20 mm)
Stop SW 5 / 5,5 / 6,2 / 7 / 9
Hydro-Flex sleeve

mimatic® Home of Innovations

- Circular- and Thread Milling Tools
- Cutting and Turning Tools
- RPK-Reamers with Polygonal Interface
- Driven Toolholders for CNC Machining Centers
- Driven Toolholders for CNC Turning Machines
- Multi-Spindle Technology
- Modular Quick Change Toolholders mimatic® mi
- Static Toolholders for CNC Turning Machines
- Precision Chucks
- Special Cutting Tools

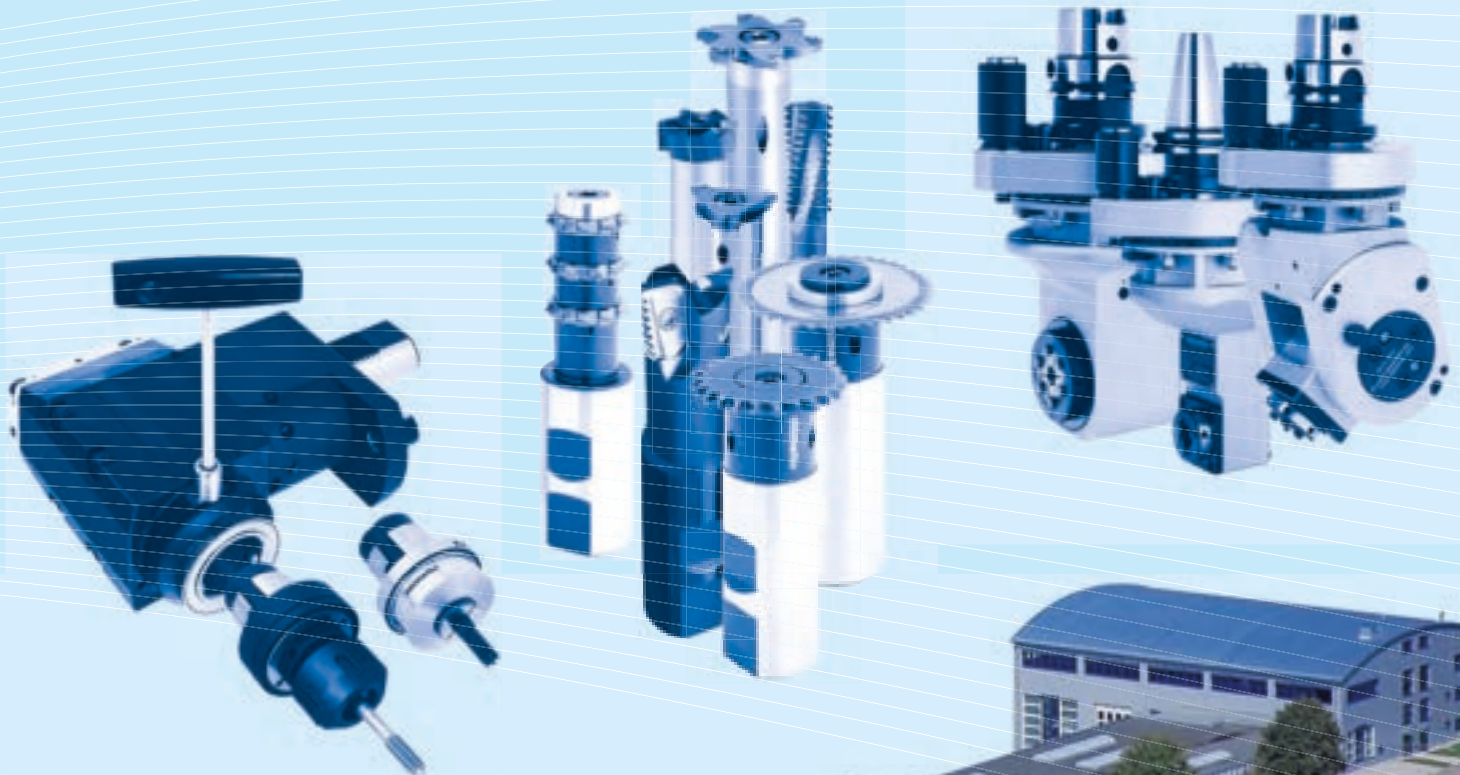

mimatic®
T o o l S y s t e m s



mimatic GmbH
Westendstraße 3
D-87488 Betzigau
Phone +49 (0) 831 / 5 74 44-0
Fax +49 (0) 831 / 5 74 44-90
info@mimatic.de
www.mimatic.de